

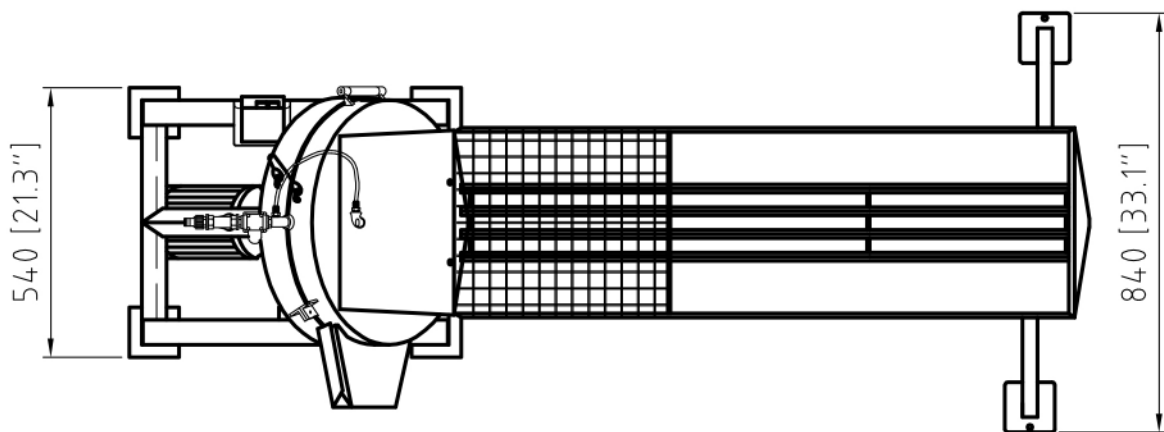

RANGE SERVANT

www.rangeservant.us

BALL WASHER 1950

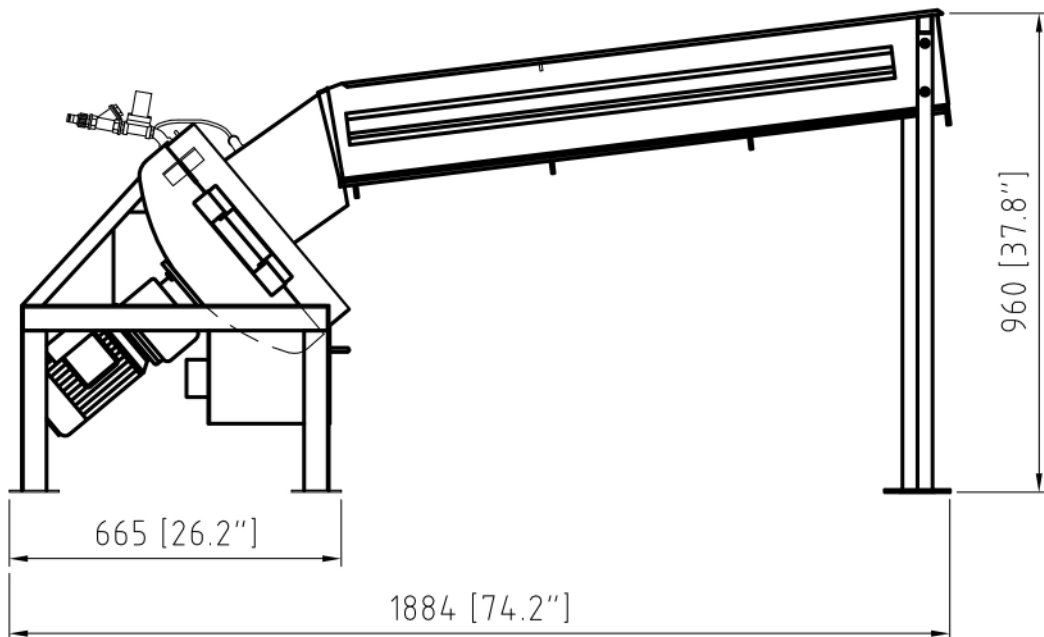

HOPPER CAPACITY	1000 BALLS
WASHING CAPACITY	400 BALLS/MIN
MOTOR	0.55 KW
VOLTAGE	110 V, 60 HZ
PLUMBING CONNECTION	R 1/2"
WATER CONSUMPTION	1 GALLON/MIN
WATER PRESSURE	1,96 - 12 BAR